

DMD15-13 Operating Manual

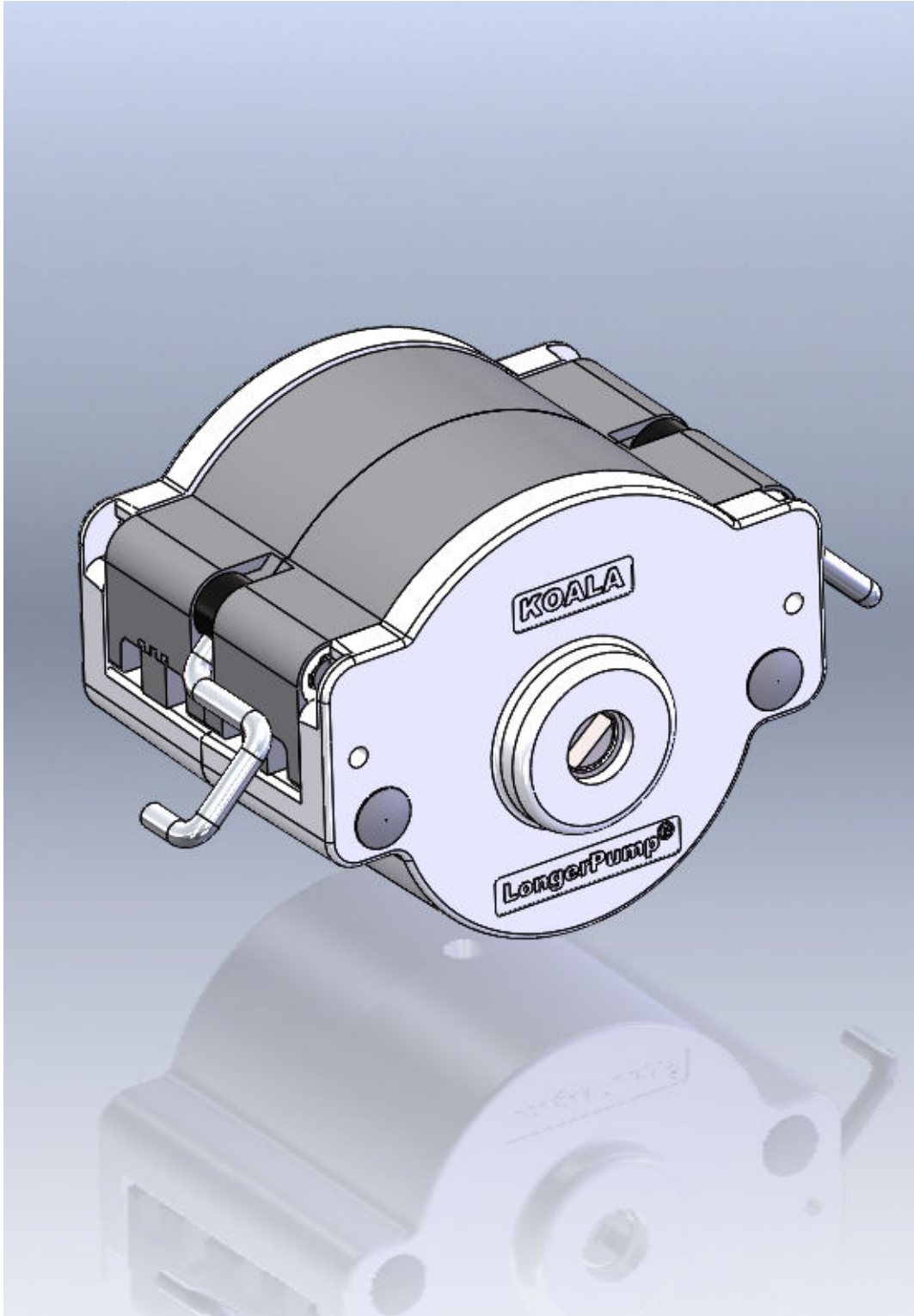

Contents

1 General Information.....	1
1.1 Precaution	1
1.2 Warranty and Service.....	1
1.2.1 Warranty Service	1
1.2.2 Maintenance Service	2
1.2.3 Service Commitment	2
1.2.4 Dispute Settlement	2
1.3 Repair Notes	2
1.4 Contacts Information	2
2 Product Introduction	3
2.1 Main Function and Features	3
2.2 Technical Specification	3
2.3 Unpacking	4
2.4 System Structure.....	4
2.4.1 Outline Drawing	4
2.4.2 Pump Head Structure	5
2.5 Working Condition	5
3 System Mounting.....	5
3.1 Single Pump Head Mounting	6
3.2 Two Pump Heads Stacking	6
3.3 Tubing Loading.....	7
4 Transportation and Storage	8



Please read this operating manual carefully before using the product.

The contents of this publication are presented for informational purposes only, and while every effort has been made to ensure their accuracy. Longer accepts no liability for errors or omissions.

Longer reserves the right to modify or improve the designs or specifications of such products at any time without notice. Please contact with Longer or certified distributor for up-to-date manuals.

1 General Information

1.1 Precaution

If tubing leaks or bursts, fluid may spray from the tubing and pump head. Take reasonable practicable measures to ensure the operators' safety. Check the tubing frequently and replace the tubing if necessary to protect the operators and device.

Make sure fluid in the tubing has been drained out, no pressure in the pipeline and disconnect pump from mains power, while removing or replacing the tubing.

Do not open the pump head while the pump is running.

Remove the tubing when pump stop running for a long time to avoid tubing deformation caused by squeezing.

Keep the rotor clean and dry to avoid tubing excessive wear and premature failure of pump head or drive.

The pump head housing surface can be scratched easily because of the plastic material. Please clean the pump head by water flushing or a soft cotton cloth wiping.

Do not disassemble, change or repair the pump head by yourself. Please contact Longer Pump or the distributor if the repair is necessary.

1.2 Warranty and Service

1.2.1 Warranty Service

(1) Longer, obligation under this warranty is limited to a period of one (1) year from the date of original purchase. Within the 1 year of warranty period, Longer will replace or repair any defective parts free of charge. This warranty doesn't cover consumable part (tubing).

(2) Warranty does not cover:

- The repair or exchange of the entire unit after the warranty period.
- Any damage or failure caused by improper installation, storage, maintenance or usage, not in compliance with operating manual.
- Beyond or violate the conditions listed in contract or technical agreement.
- Any damage or failure caused by attempts by personnel other than authorized Longer representatives to install, repair, modify or remove the product.
- Any damage or failure caused by non-Longer parts, or user-replaceable parts purchased from unauthorized distributors.
- Any damage or failure caused by accidents or human errors (including wrong power supply voltage, corrosion, fall-off, etc.)
- Any damage or failure caused by natural disaster or other irresistible force (earthquake, fire, etc.).
- Other product damage or failure not caused by defects in design, material and workmanship.

1.2.2 Maintenance Service

- Customer will be charged for the repair or replacement of the parts or accessories after warranty period.
- Parts can be replaced within 3 working days. Longer will inform customer of the date in advance if out of 3 working days.

1.2.3 Service Commitment

- Longer commits to provide customer solutions to any quality complaint within 2 working days.
- Longer commits to reply to customer's requirement of on-site technical supports or training within 2 working days.

1.2.4 Dispute Settlement

Dispute over product quality or service will be handled according to contract or agreement. If there is no related contract or agreement, it shall be resolved by the disputing parties through consultation. Otherwise, it will be resolved according to relevant national laws and regulations.

1.3 Repair Notes

Please contact Longer or its distributor, and provide the product serial number before returning the product. Products which has been contaminated with, or exposed to, toxic chemicals or any other substance hazardous to health must be decontaminated before returning to Longer or its distributor. You must ship the product in its original packaging or better, to insure it against possible damage or loss during the transport.

1.4 Contacts Information

Baoding Longer Precision Pump Co., Ltd
Building A, Chuangye Center, Baoding National
High-Tech Industry Development Zone
Baoding, Hebei, China 071051
Email: longer@longerpump.com
Tel: 86-312-3110087
Fax: 86-312-3168553
www.longerpump.com

2 Product Introduction

DMD15-13 pump head has two groups of rotor with phase compensation structure to achieve low pulse performance. Two levers are used to remove the compression block from the pump head easily, which is convenient for tubing loading and replacing. The separating block on the compression block can clamp multiple sizes of tubing with fittings or stops. Roller is made of 304 stainless steel with good corrosion resistance. Housing is made of PESU, which has good corrosion resistance, rigid and stable performance.

Table 1: Product List

Product Model	Description	Product Code
DMD15-13-A	Short shaft, low pulse pump head only for FB16-1 dispensing & filling system	05.01.04A
DMD15-13-B	Long shaft, low pulse pump head for Longer pump drive with standard pump head mounting bracket	05.01.04B

2.1 Main Function and Features

- The compression block can be removed from pump head by two levers, which is convenient for tubing loading.
- Pump head housing and compression block are made by PESU, the structure strength is reliable.
- Pump head has two groups of rotors (3 rollers/group) with phase compensation structure to achieve low pulse performance.
- Two pump heads can be stacked together.
- Roller is made of 304 stainless steel, housing is made of PESU. The pump head has good corrosion resistance.

2.2 Technical Specification

	Tubing Fitting Assembly	Silicone	PharMed
Flow Rate	2*13# tubing	0.1-76.6ml/min	0.1-80.0 ml/min
Reference	2*14# tubing	0.5-300.3ml/min	0.4-290.2 ml/min
(Speed Range:	2*19# tubing	0.8-509.5ml/min	1.0-619.9 ml/min
1-600 rpm)	2*16# tubing	1.5-854.4ml/min	1.7-963.4 ml/min
	2*25# tubing	3.4-2071.1ml/min	3.3-2058.7 ml/min
Material	Rotor	304 stainless steel (group number: 2; roller number: 3/group)	
	Housing	PESU (white color)	
	Compression Block	PESU (white color)	
	Tubing Fitting	PP	

2.3 Unpacking

To unpack the pump head, follow below steps:

- 1) Take out the pump head and accessories from the shipping carton.
- 2) Check the packing list to make sure all components are present.
- 3) Contact Longer Pump or distributor for any question.

2.4 System Structure

2.4.1 Outline Drawing

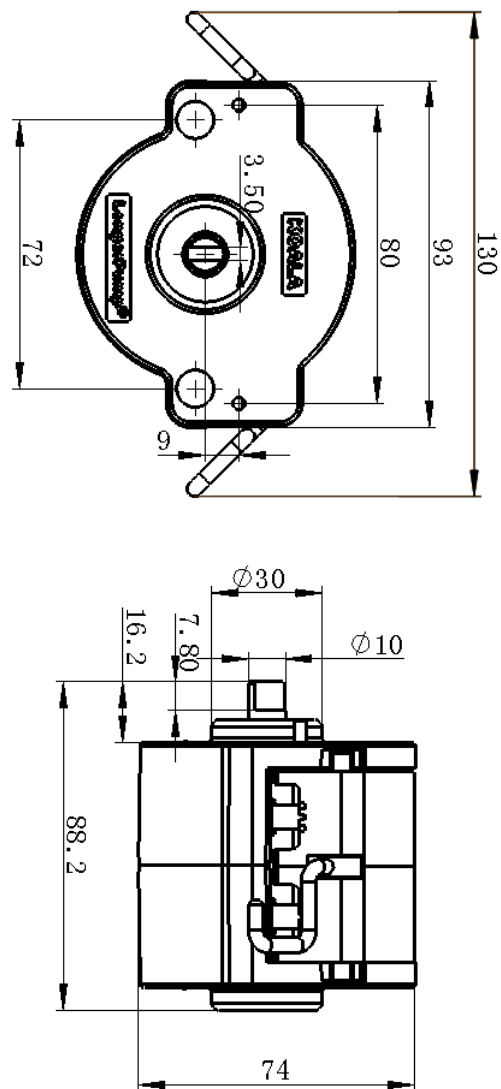

Figure 1 Outline Drawing

2.4.2 Pump Head Structure

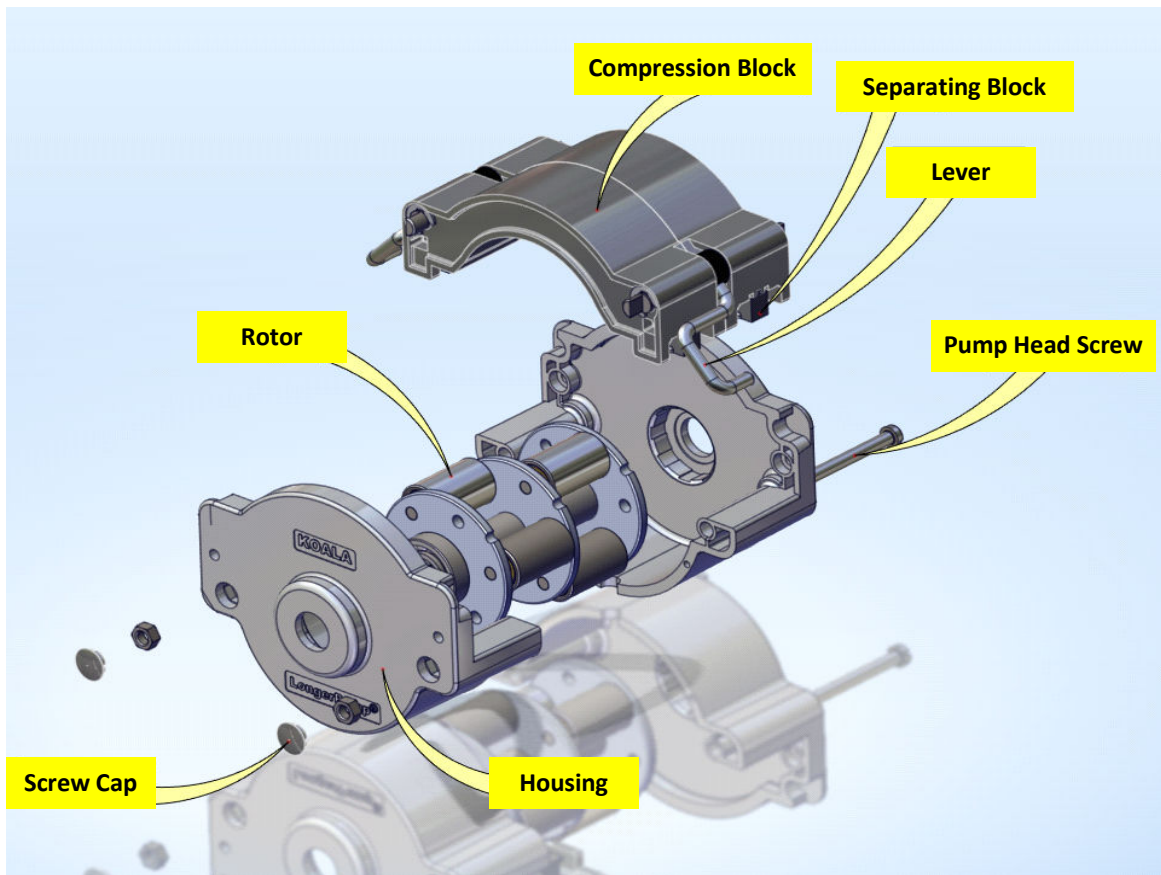

Figure 2 System Structure

2.5 Working Condition

Working Temperature: 0°C-40°C

Relative Humidity: ≤85%

3 System Mounting

DMD15-13-A: Pump head only for FB16-1 dispensing & filling system, please refer to <FB16-1 Operating Manual> for DMD15-13-A mounting instruction.

DMD15-13-B: Pump head for Longer pump drive with standard pump head mounting bracket. Below mounting instruction is only for DMD15-13-B.

3.1 Single Pump Head Mounting

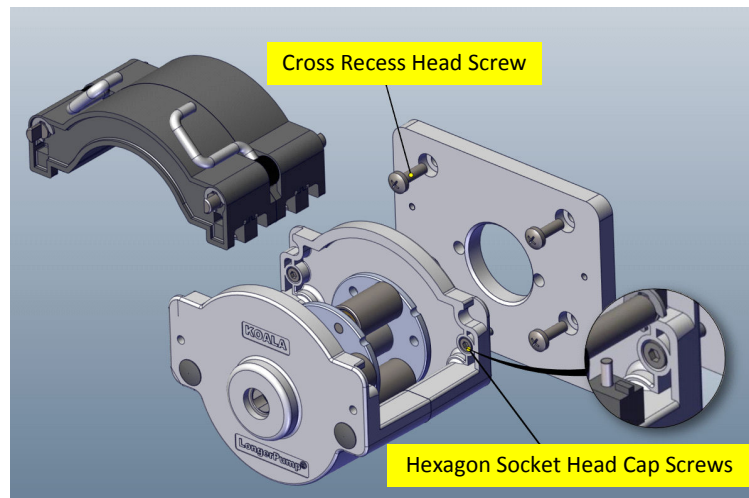

Mounting steps:

- a) Mount the mounting plate: Mount the mounting plate on the pump drive by using 4 cross recess head screws M4X10.
- b) Mount single pump head: release the two levers to open the pump head and remove the compression block. Insert the tang of the pump head shaft into the slot of the motor shaft. Press the pump head firmly against the mounting plate. Turn the pump head to align the mounting holes on the pump head with the mounting holes on the mounting plate. Insert the two mounting screws (hexagon socket head cap screw M3X10) into the mounting holes, then tighten them.

Note:

Please disconnect pump from the mains power before replacing the pump head.

3.2 Two Pump Heads Stacking

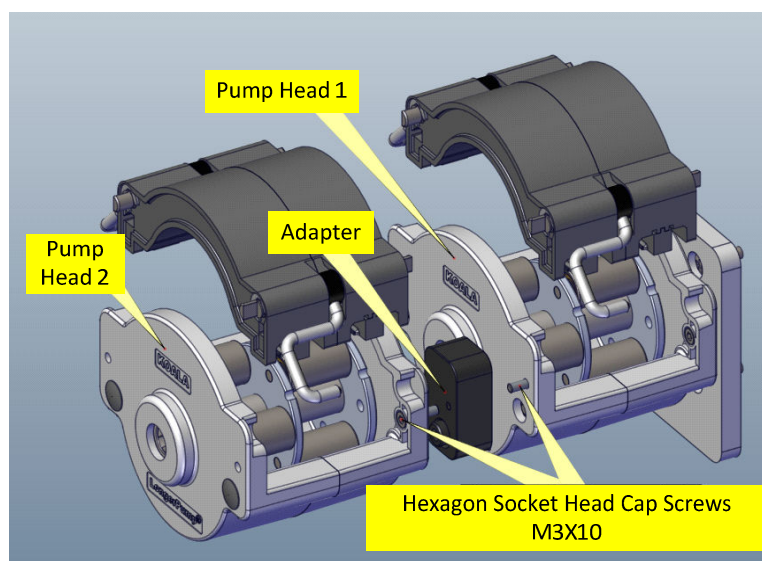

Mounting steps:

- a) Mount the mounting plate: Mount the mounting plate on the pump drive by using 4 cross recess head screws M4X10.
- b) Mount pump head 1: release the two levers of pump head 1 to open the pump head and remove the compression block. Insert the tang of the pump head shaft into the slot of the motor shaft. Press the pump head firmly against the mounting plate. Turn the pump head to align the mounting holes on the pump head with the mounting holes on the mounting plate. Insert the two mounting screws (hexagon socket head cap screw M3X10) into the mounting holes, then tighten them.
- c) Mount the adapter: Mount the adapter on the pump head 1 by using 2 hexagon socket head cap screws M3X10.
- d) Mount pump head 2: release the two levers of pump head 2 to open the pump head and remove the compression block. Insert the tang of the pump head 2 shaft into the slot of the pump head 1 shaft. Press the pump head 2 firmly against the adapters. Turn the pump head 2 to align the mounting holes of pump head 2 with the mounting holes on the adapter. Insert the two mounting screws (hexagon socket head cap screw M3X10) into the mounting holes, then tighten them.

Note:

Please disconnect pump from the mains power before replacing the pump head.

3.3 Tubing Loading

Load the tubing according to below steps:

- 1) Release the levers to remove the compression block.

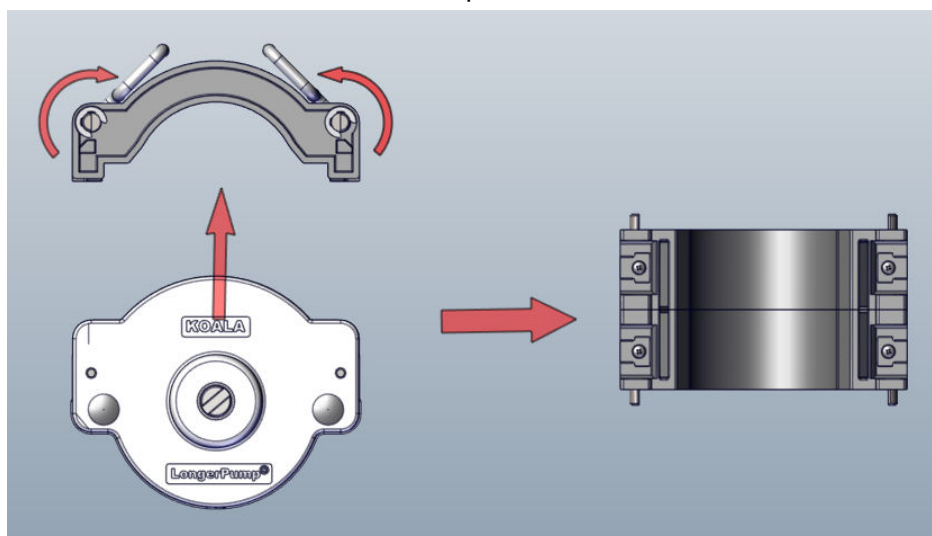

- 2) Insert the tubing fitting assembly into the compression block.

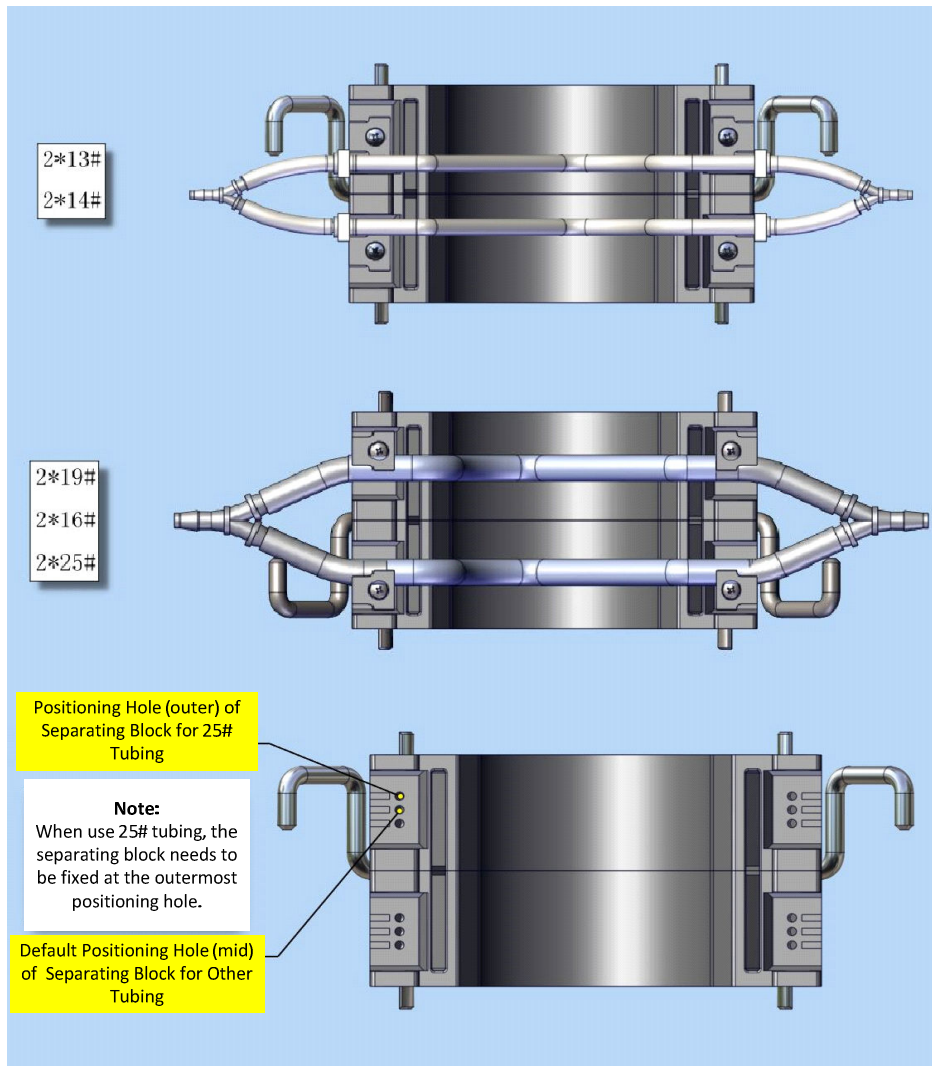

- 3) Put the compression block with tubing fitting assembly back to the pump head, and lock the levers.

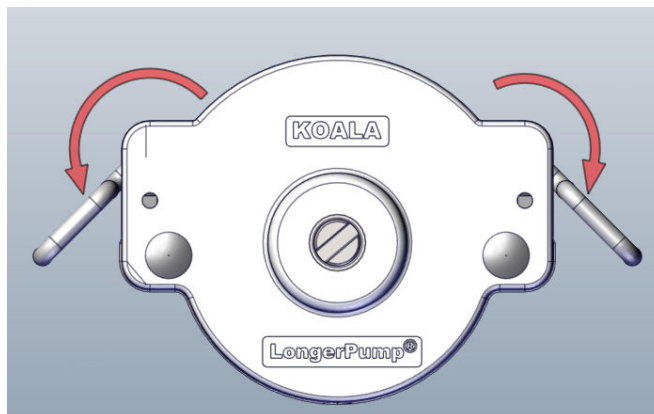

4 Transportation and Storage

- In the process of transportation, prevent water, moisture, insect, corrosion, and strong mechanical vibration.
- The pump head should be stored in shipping carton. The environment should keep air circulation. The environment temperature should be $-10^{\circ}\text{C}\sim 40^{\circ}\text{C}$ and relative humidity

should be $\leq 85\%$. Warehouses are not allowed to have all kinds of poisonous, harmful, flammable, explosive and corrosive chemicals.