

NOTE: FOR MORE DETAILS SEE YOUR V.P.CUSTOMER SERVICE REP.

REVISIONS			
REV.	DESCRIPTION	DATE	APPROVED
A	INITIAL RELEASE	11-05-02	
B	CO 027 Drafting Update	10-04-05	Rick C.

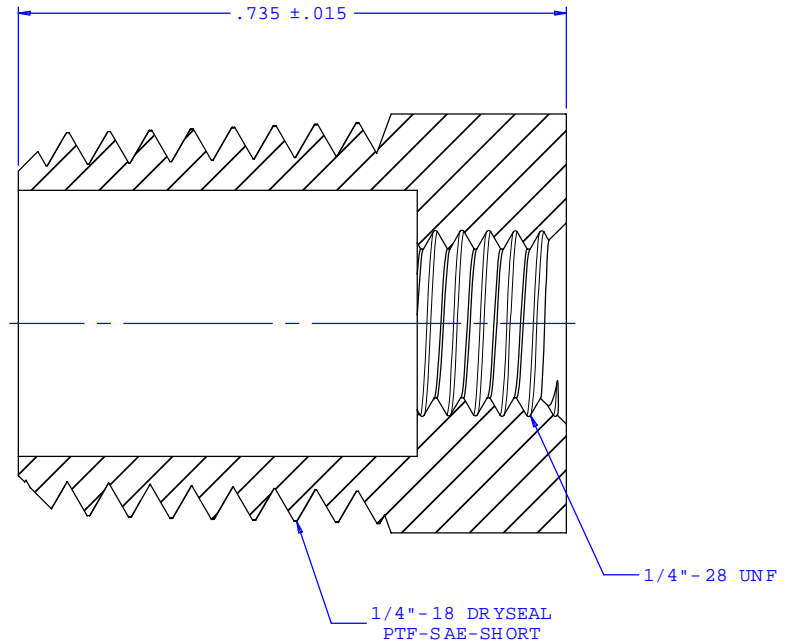

SECTION B-B

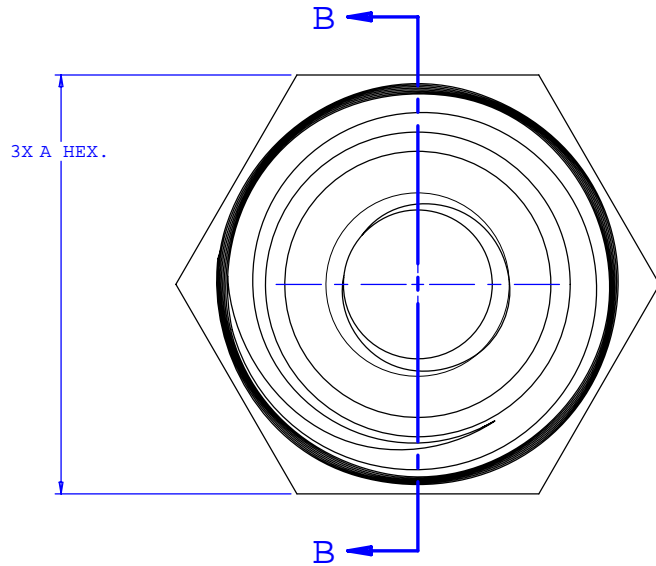
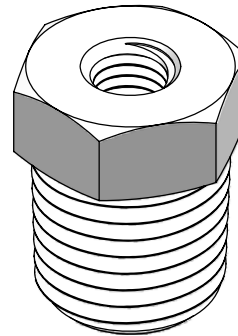

Dimension	Material Specific Tolerances							
	Acetal	Nylon	PP	ABS	PC	PVC	Polysulfone	J1A
A	.555	.555	.555	.555	.555	.555	.555	.550
B								
C								
D								
E								
F								

UNLESS OTHERWISE SPECIFIED DIMENSIONS ARE IN INCHES TOLERANCES ARE:		VALUE PLASTICS, INC.	
FRACTIONS ±	DECIMALS .XX ±.01 .XXX ±.005 .XXXX ±.001	ANGULAR ±1°	PART NUMBER: 1402
DO NOT SCALE DRAWING		DESCRIPTION: Reducer with 1/4-18 NPT Male Thread and 9/16"Hex to 1/4-28 UNF Female Thread	
DRAWN BY: Frank Lombardi	DATE: 09-01-05	SIZE: B	SCALE: NTS
Engineer/Manager: Rick Cairns		DRAWING NUMBER: 1007449	REV. B
© 2005 VALUE PLASTICS, INC.		SHEET: 1 OF 1	

FOR REFERENCE ONLY